

WAREFORCE® CG-115

Project _____
Item _____
Quantity _____
CSI Section 11400 _____
Approval _____
Date _____

Models

WAREFORCE CG-115



Standard Features

- Cleans 1,200 glasses an hour
- 12" clearance allows cleaning of taller stemware, glasses and mugs
- Composite carousel conveyor prevents chipping and damage to glasses, mugs and stemware
- Low-water protectors for pump and wash heating element
- Quick-removal side panel allows tool-free access to vacuum breakers for ease of service
- Simplified, front access to all controls and chemical settings
- Efficient 1/10 hp wash pump
- Conveniently located conveyor drive motor
- Single-switch, auto-fill operation
- Convenient, expanded chemical storage inside machine
- Built-in chemical pumps and priming switches
- Wash/rinse temperature gauges
- Durable stainless steel construction
- Adjustable rinse control allows hot or cold water final rinses for flexible sanitizing methods
- Adjustable bullet feet
- Unit fits compactly underbar
- Removable wash/rinse arms with removable end caps on (both lower and upper) wash/rinse arms combine for ease in cleaning
- Double-wall cabinet for quiet operation and less heat loss

Accessories/Options

- Scrap tray
- Scale Prevention System (SPS)
- Replacement Cartridge for SPS

Specifications

12" (305 mm) wash clearance

Quick-removal side panel allows tool-free access to vacuum breakers

Efficient 1/10 hp wash motor

Low-water protection for wash pump and wash tank heating element

Automatic conveyor system with composite carousel to prevent damage to glasses, mugs and stemware

Cleans 1,200 glasses per hour

Gravity drain

Removable end caps on (both lower and upper) wash and rinse arms for cleaning

Built-in chemical pumps and priming switches

Solid-state and electromechanical components

Clockwise rotation is standard

Durable stainless steel construction



WAREFORCE®

WAREFORCE® CG-115

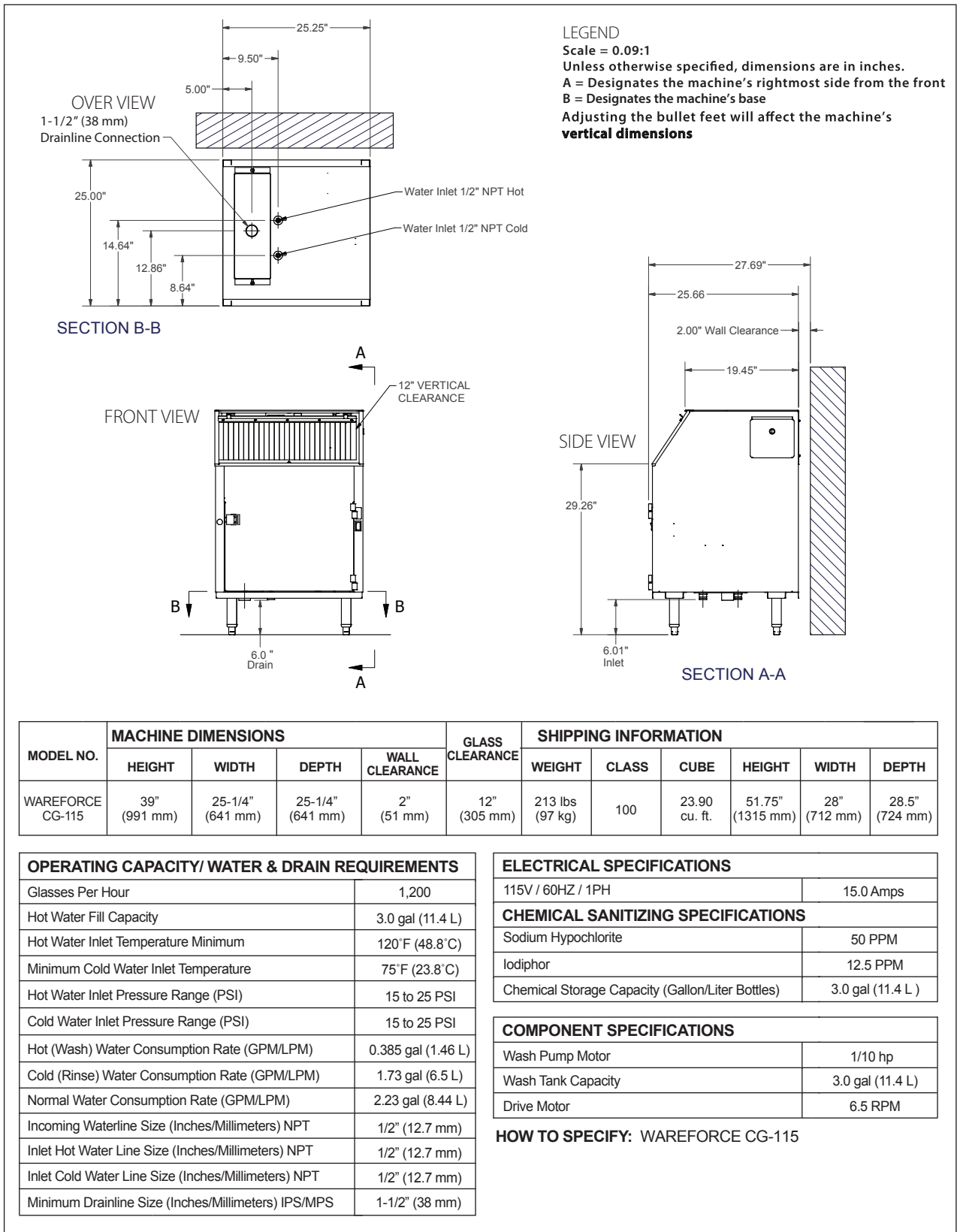

MODEL NO.	MACHINE DIMENSIONS				GLASS CLEARANCE	SHIPPING INFORMATION					
	HEIGHT	WIDTH	DEPTH	WALL CLEARANCE		WEIGHT	CLASS	CUBE	HEIGHT	WIDTH	DEPTH
WAREFORCE CG-115	39" (991 mm)	25-1/4" (641 mm)	25-1/4" (641 mm)	2" (51 mm)	12" (305 mm)	213 lbs (97 kg)	100	23.90 cu. ft.	51.75" (1315 mm)	28" (712 mm)	28.5" (724 mm)

OPERATING CAPACITY/ WATER & DRAIN REQUIREMENTS	
Glasses Per Hour	1,200
Hot Water Fill Capacity	3.0 gal (11.4 L)
Hot Water Inlet Temperature Minimum	120°F (48.8°C)
Minimum Cold Water Inlet Temperature	75°F (23.8°C)
Hot Water Inlet Pressure Range (PSI)	15 to 25 PSI
Cold Water Inlet Pressure Range (PSI)	15 to 25 PSI
Hot (Wash) Water Consumption Rate (GPM/LPM)	0.385 gal (1.46 L)
Cold (Rinse) Water Consumption Rate (GPM/LPM)	1.73 gal (6.5 L)
Normal Water Consumption Rate (GPM/LPM)	2.23 gal (8.44 L)
Incoming Waterline Size (Inches/Millimeters) NPT	1/2" (12.7 mm)
Inlet Hot Water Line Size (Inches/Millimeters) NPT	1/2" (12.7 mm)
Inlet Cold Water Line Size (Inches/Millimeters) NPT	1/2" (12.7 mm)
Minimum Drainline Size (Inches/Millimeters) IPS/MPS	1-1/2" (38 mm)

ELECTRICAL SPECIFICATIONS	
115V / 60HZ / 1PH	15.0 Amps
CHEMICAL SANITIZING SPECIFICATIONS	
Sodium Hypochlorite	50 PPM
Iodophor	12.5 PPM
Chemical Storage Capacity (Gallon/Liter Bottles)	3.0 gal (11.4 L)

COMPONENT SPECIFICATIONS	
Wash Pump Motor	1/10 hp
Wash Tank Capacity	3.0 gal (11.4 L)
Drive Motor	6.5 RPM

HOW TO SPECIFY: WAREFORCE CG-115

WAREFORCE®

Shipping Address: 6209 North U.S. Highway 25E, Gray, KY 40734
 Mailing Address: P.O. Box 1060, Barbourville, KY 40906
 Telephone: 888-800-5672 • Fax: 606-523-1799
 Email: info@jacksonwws.com
 07610-004-28-05 [03/30/17]

We reserve the right to change specifications in this bulletin without incurring any obligation for equipment previously or subsequently sold.