



**GL-X**

Chemical Sanitizing  
Glasswasher



**MODEL GL-X**

**FEATURES:**

- 30 racks per hour.
- Economical to operate. Uses only 1.7 gallons of water per cycle.
- All stainless steel construction assures long life and years of trouble free operation.
- Unique spray arm system features upper and lower stainless steel wash arms with reinforced end caps.
- Built-in chemical pumps and delimiting system assures proper chemical usage.
- Convenient to service "Works-in-a-drawer". All electrical components are attached to a sliding drawer for easy access and service.
- Instant start for simple operation.
- Built-in Hot Water Assurance System guarantees hot water every cycle.
- Pumped drain allows for flexible installations. No floor drain required.
- Wash tank sustainer heater keeps water at proper temperature between loads.

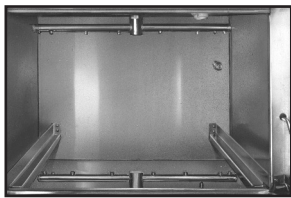

Upper and lower rotating wash arms guarantee excellent results.



Uses standard 19-3/4" X 19-3/4" racks. Large 11-1/4" glass clearance.

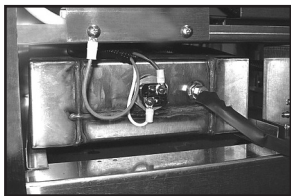

"Built in" Hot Water Assurance System provides hot water every cycle.



"Works-in-a-drawer". All electrical components are attached to a sliding drawer for easy access and service.

**Available Options**

- Sanitizer Alarm





**GL-X**  
Chemical Sanitizing  
Glasswasher

**WARNINGS:**

- Plumbing connections must be made by a qualified service company who will comply with all available Federal, State, and Local Health, Plumbing and Safety codes.
- Water hardness above 3 grains per gallon should be treated by a water softener. Failure to provide soft water (3g or less) will void the machine warranty.

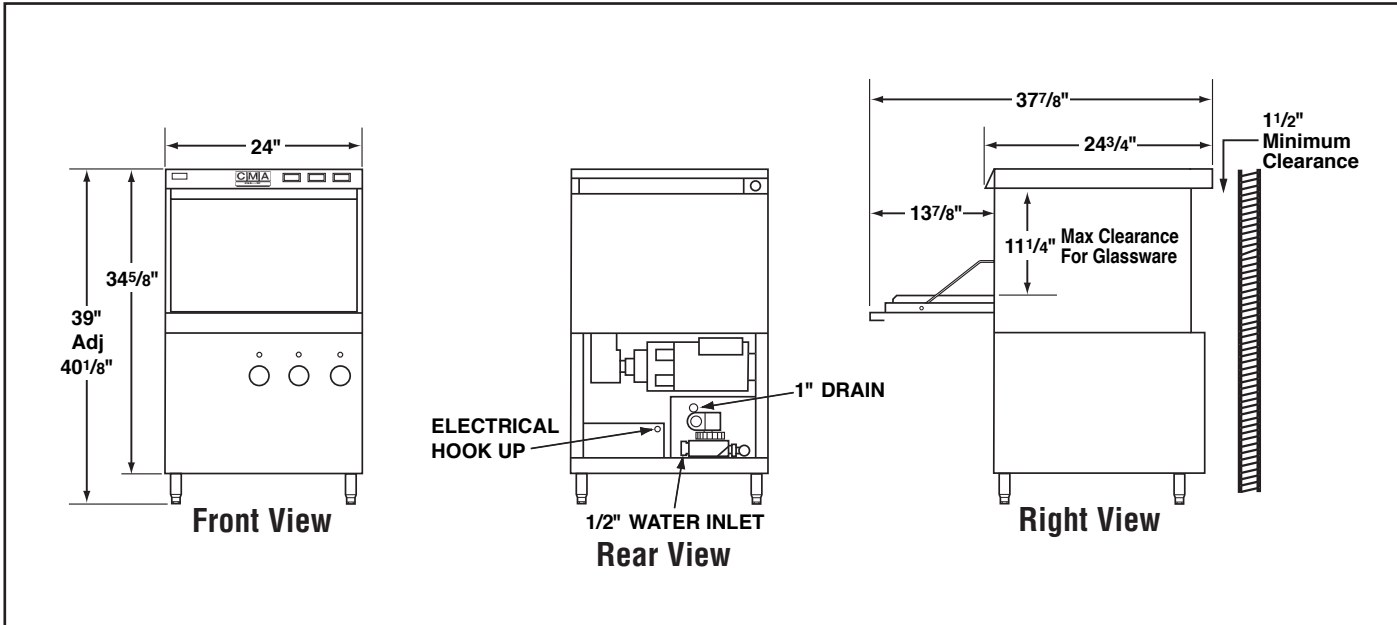

**Specifications:**

MODEL GL-X	USA	METRIC	USA	METRIC
<b>OPERATING CAPACITY</b> RACKS PER HOUR	30	30	<b>WASH PUMP MOTOR HP</b>	1
<b>OPERATING CYCLE</b> WASH TIME-SEC	58	58	<b>DIMENSIONS</b> DEPTH	24-3/4" (63cm)
RINSE TIME-SEC	32	32	WIDTH	24" (61cm)
DWELL/TIME-SEC	30	30	HEIGHT	39"-40-1/8" (99-102cm)
TOTAL CYCLE TIME	120	120	MAXIMUM CLEARANCE FOR GLASSWARE	11-1/4" (28.57cm)
WASH TANK CAPACITY	1.7 GAL. (6.45 L)		<b>STANDARD DISHRACK</b> DIMENSIONS	19-3/4"X19-3/4" (50X50cm)
WASH PUMP CAPACITY	35 GPM (132 LPM)		<b>ELECTRICAL RATING</b> VOLTS	115
<b>MINIMUM TEMPERATURE REQUIRED</b> WASH TEMP.	120°F (50°C)		AMPS	16
<b>WATER CONSUMPTION</b> PER RACK	1.7 GAL. (6.45 L)		<b>SHIPPING WEIGHT</b> APPROXIMATE	244# (110.6kg)
PER HOUR	40.8 GPH (154.4 LPH)			
WATER INLET	1/2"	(1.27 cm)		
DRAIN	1"	(2.54cm)		

**Summary Specifications: Model GL-X**

The GL-X glasswasher is designed to produce sparkling clean glassware utilizing our unique Hot Water Assurance System. The GL-X is easy to use, fast and efficient, while conserving water, energy and chemicals. Built-in sustainer heater provides continuous 130°F hot water every cycle. The GL-X is constructed entirely of stainless steel and is equipped with an integrated chemical delivery system. The GL-X incorporates a pump purging system that improves results by eliminating soil and chemical carryover during rinse cycle.

**Advisory:** CMA does NOT endorse "Tankless On-Demand" water heaters for use on CMA Dishmachine products. CMA DOES endorse, and highly recommends, the standard "tank" style water heaters, sized properly to handle each particular facility with their water heating requirements.

